

miniVE

Electrophoresis and Electrotransfer Unit

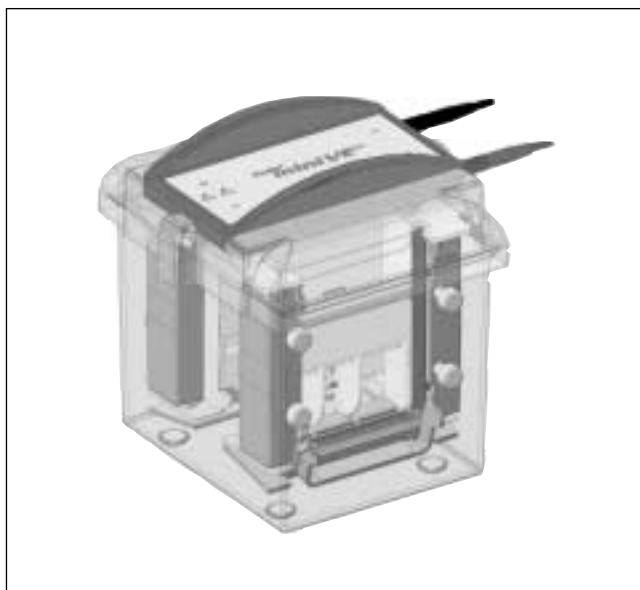

User Manual

1 Hoefer miniVE Electrophoresis Unit Function and Description

The Hoefer miniVE vertical electrophoresis system performs vertical gel electrophoresis on mini-format gels. The basic unit includes two electrophoresis modules. Each module holds one gel sandwich, 10 cm wide and 8 to 10.5 cm long. One gel can be cast in place on the electrophoresis module.

A wide range of accessories, ordered separately (see Section 5), lends the miniVE a high degree of versatility. These include:

- + a large selection of combs and spacers,
- + adaptor sleeves to run Novex precast gels,
- + and a blot module, which converts the miniVE into a mini blotting unit. (See page 17 for instructions.)

Figure 1.1
Main components

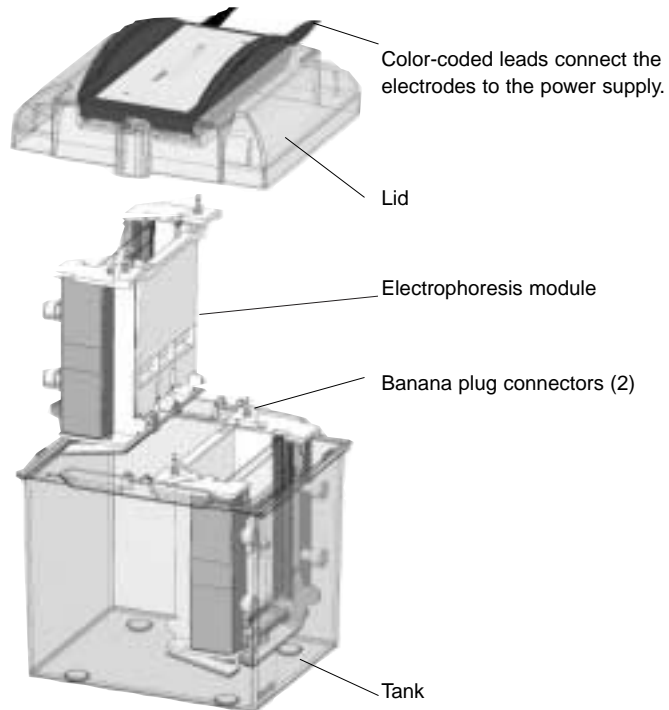

Power supply minimum ratings:
50 mA, 250 V
Constant current or constant voltage

1.1 Specifications

Electrophoresis

Gel sandwich size	10.0 cm wide × 8 to 10.5 cm long
Max. tank volume	1.7 liters with one module in place 1.2 liters with two modules in place
Max. voltage	600 V ⁻⁻⁻
Max. wattage	25 W per electrophoresis module

Electrotransfer

Max. volume (blot module)	350 ml per module
Max. tank volume (for passive cooling)	1.7 liters with one module in place 1.2 liters with two modules in place
Max. wattage	15 W per blot module
Max. current	400 mA

miniVE specifications

Max. operating temperature	75 °C
Chemical compatibility	For use only with dilute aqueous solutions between pH 2 and pH 12. Not compatible with organic solvents or concentrated alcohols, acids, bases, and oxidizing agents.
Environmental operating conditions	Indoor use: 4–40 °C Humidity up to 80% Altitude up to 2000 m
Installation category	II
Pollution degree	2
Dimensions (w × d × h)	19.2 × 17.2 × 18.8 cm (7.6 × 6.8 × 7.4 in.)
Weight (tank, lid, and two gel modules)	1.2 kg (2.65 lbs)
Product certifications	EN61010–1, UL3101–1, CSA C22.2 1010.1, CE

This declaration of conformity and the warranty are only valid when the instrument is:

- ▶ used in laboratory locations,
- ▶ used within the conditions specified in the User Manual,
- ▶ used as delivered from Amersham Biosciences except for alterations described in the User Manual, and
- ▶ connected to other CE labeled instruments or products recommended or approved by Amersham Biosciences.

1.2 Important Information

- ▶ The safety lid must be in place before connecting the power leads to a power supply.
- ▶ Turn all power supply controls off and disconnect the power leads before removing the safety lid.
- ▶ Do not operate with the gel or buffer temperature above 75 °C. Overheating will cause irreparable damage to the unit! Chilled buffer provides passive cooling that can help control overheating to some degree.
- ▶ To clean the safety lid, wipe with a damp towel or briefly rinse the underside *only*. Do not immerse.
- ▶ Do not autoclave or boil this unit or any of its parts.
- ▶ Do not remove the screws in the clamps; four full turns in the counterclockwise direction are sufficient to be able to open the clamps.
- ▶ If this equipment is used in a manner not specified by the manufacturer, the protection provided by the equipment may be impaired.
- ▶ Only accessories and parts approved or supplied by Amersham Biosciences may be used for operating, maintaining, and servicing this product.



1.2 Informations importantes

- ▶ Le couvercle de sécurité doit être en place avant de brancher les prises au générateur.
- ▶ Eteindre le générateur et débrancher les prises avant d'enlever le couvercle de sécurité.
- ▶ Ne pas travailler avec un gel ou un tampon dont la température dépasse 75 °C. Une surchauffe causerait des dommages irréparables à l'unité d'électrophorèse ! En dessous de conditions normales, veuillez à prévenir d'une surchauffe en refroidissant le tampon avant l'utilisation.
- ▶ Pour nettoyer le couvercle de sécurité, essuyer avec un chiffon humide ou rincer uniquement le dessous. Ne pas immerger.
- ▶ Ne pas autoclaver ou stériliser cette unité, ni aucune de ses pièces détachées.
- ▶ Ne pas enlever les vis des pinces ; pour ouvrir les pinces, il suffit de tourner quatre fois dans le sens inverse des aiguilles d'une montre.
- ▶ Si l'instrument n'est pas utilisé en conformité avec les recommandations du fabricant, les protections de sécurité qui équipent cet appareil peuvent être rendues inefficaces.
- ▶ Seulement les accessoires et pièces détachées approuvés ou fournis par Amersham Biosciences sont recommandés pour l'utilisation, l'entretien et réparation de cet appareil.

1.3 Unpacking

1. Unwrap all packages carefully and compare contents with the packing list, making sure all items arrived. If any part is missing, contact your local sales office. Inspect all components for damage that may have occurred while the unit was in transit. **If any part appears damaged, contact the carrier immediately.** Be sure to keep all packing material for damage claims or for repacking should it become necessary to return the unit.
2. Prior to use, wash the tank and module with a dilute solution of non-abrasive laboratory detergent. Thoroughly rinse first with water and then with distilled water.

2

The Electrophoresis Module

This section describes the use of the electrophoresis module. For instructions on using the blot module, see page 17.

2.1 Preparing the gel

Both self-cast and precast gels of the following dimensions fit the electrophoresis module: 10 cm wide, 8 to 10.5 cm long, 0.75 to 1.5 mm thick. For instructions for precast gels, see section 2.1.2.

2.1.1 Self-cast gels

One single gel can be cast on the module. To cast several gels, a multiple gel caster such as the Hoefer SE 215, SE 235 Mighty Small 4-Gel, SE 245 Mighty Small Dual Gel Caster, or SE 275 Mighty Small Multiple Gel Caster is required (see ordering information).

Figure 2.1
Module in the closed position

1. Position the module to accept the gel sandwich. Each of the three sealing elements is hinged, and must be placed in the open position:

a) Release the sealing plate by applying gentle pressure to both tabs as indicated by the arrows. Then, holding the tabs, move the plate into the fully open position.

b) Loosen all four screws 4–5 turns in the counter-clockwise direction.

c) Swing the clamps outward.

Lay the module flat on a work surface.

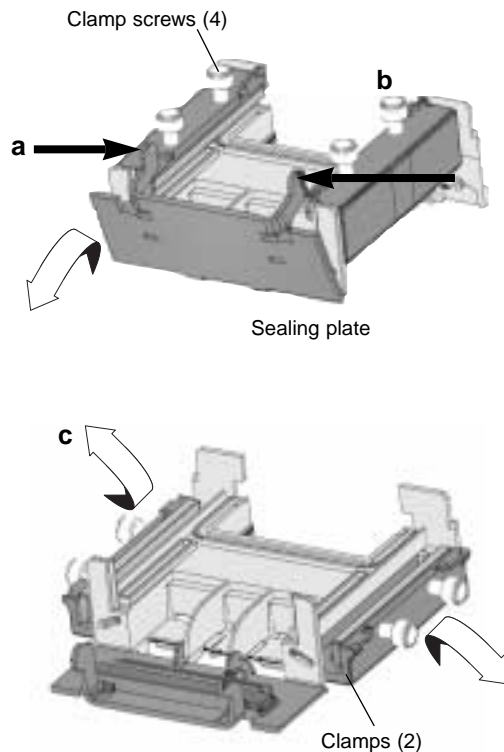

Figure 2.2
Module in the open position

Note

The sealing plate has three positions: closed (sealed for casting), half open (for electrophoresis), and fully open (for placing the gel sandwich).

2. Assemble the gel sandwich.

Figure 2.3
Gel sandwich assembly

Choose one notched plate, one rectangular glass plate, and two spacers. Use only unchipped plates to prevent leaking.



Assemble the gel sandwich as shown: the notch is at the top of the sandwich and the spacer ridges align along the glass plate edges on the sides of the sandwich.

IMPORTANT: PROPER ALIGNMENT IS ESSENTIAL IN STEPS 3 AND 4 TO PREVENT LEAKAGE. TAKE CAREFUL NOTE OF THE ALIGNMENT TIPS.

3. Place the sandwich on the module.

Take care to “square” the three sealing sides of the sandwich. This can be done by holding the sandwich like a deck of cards and gently tapping the bottom against a flat surface.

Tip: Once the sandwich is carefully aligned, handle it with the flat sides firmly between your thumb and fingers, near the notch.

Notched plate side down, lay the sandwich on the module, fitting it within the guides at both sides (a) and against the guide feet at the bottom (b).

Figure 2.4
Placing the sandwich

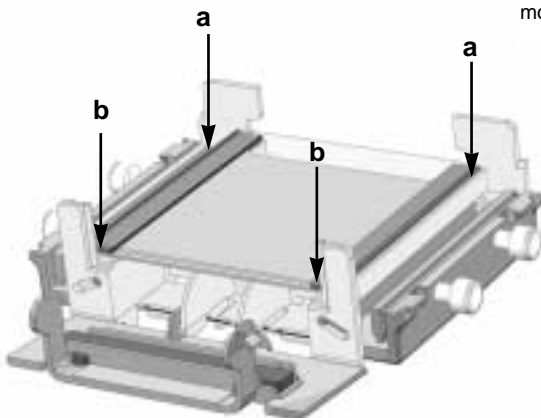

The notched plate is against the module, with the notch at the top.

The gel sandwich fits within guides at the sides and aligns flush against the guide feet at the bottom of the module.

4. Seal the sandwich.

Figure 2.5
Positioning the clamps

a) While gently holding the sandwich against the module, swing one clamp into position over the spacer, taking care not to bump the sandwich out of alignment. Turn each screw (alternating to keep the pressure even) until the clamps are loosely secured and will allow the spacers to be adjusted, if necessary. Repeat on the other side.

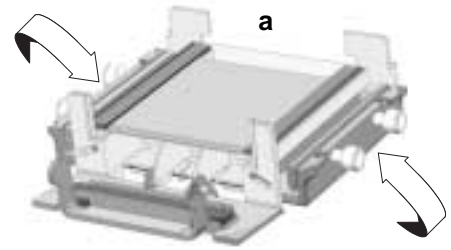

Figure 2.6
Checking the alignment

b) Important: Check the alignment at the bottom of the sandwich.

If the spacers and glass plates are not perfectly aligned against the stops, use the stiff end of the Hoefer Wonder Wedge provided to press against the edges of the spacer and glass plates to position them flush against the guide foot.

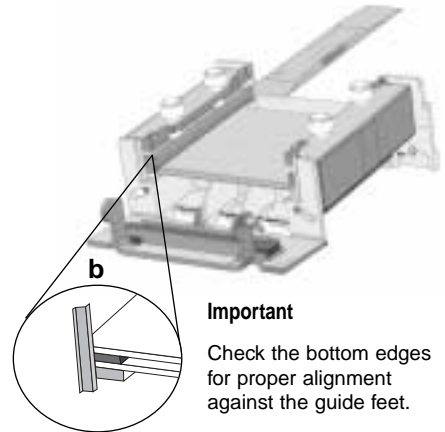

Figure 2.7
Misalignments will cause leakage

c) Complete clamping by tightening each screw firmly, hand tight. Do not overtighten, as the plates may crack. Check the spacer alignment.

Tip: A test for alignment involves passing a corner of the Wonder Wedge across the bottom edge of the spacers and glass plates. If an edge “catches,” realign. Check both sides.

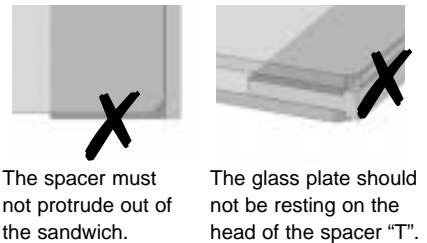

Figure 2.8
Final assembly

d) Lock the sealing plate into the closed position by engaging each tab in its topmost notch.

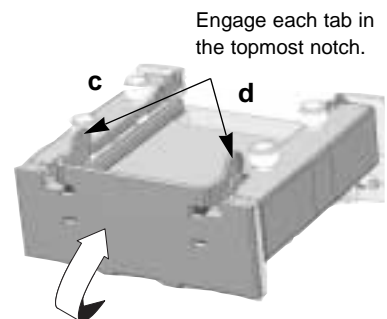

Figure 2.9
Convenient module
position for pouring the
gel

If a counterweight is required for balance, either fill the tank or hang the second module on the other side.

Tip

Approximately 10 ml of monomer solution is required to cast one 1 mm thick gel, 10×10.5 cm plates.

5. Hang the module from the side of the tank or stand it on the benchtop to cast the gel.

6. **Prepare the monomer solution and pour the resolving gel.**

Caution: Acrylamide is a neurotoxin. Always wear gloves and observe all laboratory safety procedures.

Pipet the solution into the sandwich slowly so that it flows along a spacer, taking care not to trap any air pockets.

No stacking gel: fill the solution to the desired level and then insert a comb (at a slight angle) into the sandwich, taking care not to trap air under the teeth.

For a 1 cm stacking gel below the wells, fill to 3 cm below the top of the rectangular glass plate. Overlay each gel with a thin layer of water-saturated n-butanol, water, or diluted gel buffer to prevent exposing the monomer solution to oxygen. Apply the overlay solution (100 µl) slowly to one side of the sandwich, near the spacer, using a glass syringe fitted with a 22-gauge needle. Allow the solution to flow across the surface unaided.

7. Allow a minimum of one hour for the gel to polymerize.
8. If a comb is in place, remove it by carefully pulling on the comb while gently rocking it back and forth to break the vacuum. Rinse the wells with electrophoresis buffer to remove any unpolymerized acrylamide.

If an overlay was applied, rinse the sandwich several times with double distilled water to remove it.

Invert the module to drain.

For instructions on pouring a stacking gel, see section 2.1.3.

9. If the gel is ready for electrophoresis, move the sealing plate into the “half open” position: Apply gentle pressure to both tabs and lock them into the lower notch.

Tabs on the narrow side of the tank fit into slots in the module.

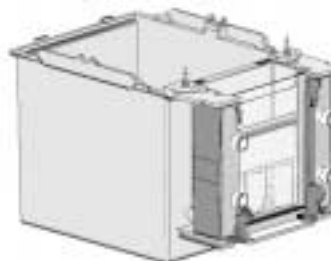

2.1.2 Precast gels

1. See Section 2.1.1, step 1 to prepare the electrophoresis module.

Figure 2.10
Installing adaptor sleeves

Novex gel cassettes only: Adaptor sleeves, ordered separately, must be installed on each clamp. Slide an adaptor sleeve on each pressure plate from the bottom, as shown in Figure 2.10. The sleeve fits in only one orientation, and snaps into place when fitted properly.

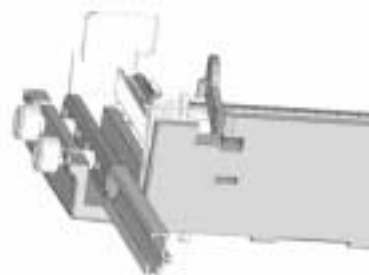

Slide the adaptor sleeve over the pressure plate.

2. Follow the manufacturer's instructions to prepare the gel for electrophoresis. This may involve removing tape or breaking off the sealing edge from the bottom of the cassette.
3. Remove the comb and rinse the wells with electrophoresis buffer to remove any unpolymerized acrylamide.

Tip: To aid in sample loading, mark the well locations with a laboratory marking pen.

Figure 2.11
Securing the cassette

4. **Position the cassette on the module.** Orient the cassette so that the notched side is against the gasket, and the wells are at the top of the module. Center the cassette within the guides at both sides of the module (a).

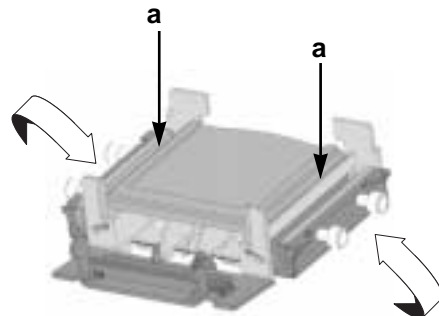

5. **Secure the cassette.** Swing each clamp into position over the sides of the cassette. Tighten each screw, alternating to apply even pressure until the cassette is secure. The gasket around the upper buffer chamber should be fully compressed to provide a seal, but the screws should not be tightened to the point that pressure stresses the cassette.
6. Check that both gel surfaces will contact buffer. Novex gels: check that the bottom gel-contact slot is exposed.
7. Move the sealing plate into the “half open” position to prepare for electrophoresis: Apply gentle pressure to both tabs and lock them into the lower notch.

2.1.3 Cast the stacking gel

1. If the gel has wells, skip to Section 2.2.
2. The gel sandwich or cassette should already be in place on the module. To ensure seamless contact between the resolving and stacking gels, remove residual liquid by blotting one corner of the gel with a lint-free tissue.
3. Prepare the stacking gel monomer solution.

Tip: To calculate the volume, measure the distance, in cm, from the top of the resolving gel to the notch in the glass plate. (This should be at least 2 cm.) Multiply this distance by the gel width (8.3 cm) and the gel thickness (cm) for the required volume (ml).

4. Deaerate the stacking gel monomer solution, add catalyst and initiator and then pour. Use a pipette to deliver the solution into one corner of the plate, taking care not to trap any bubbles. Insert a comb (at a slight angle to prevent trapping air) into the sandwich, allowing the comb sides to rest on the spacers.
5. Allow a minimum of one hour for the gel to polymerize.

Note

Stacking gel resolution is optimal if the gel is poured just before electrophoresis.

2.2 Final assembly

Figure 2.12
Preparing for electrophoresis

Note for preparative combs:

The side wells for standards are the same size as in the 10-well comb.

Note

Avoid wetting the banana plugs with electrophoresis buffer. A protective film of GelSeal™ (supplied) can be applied to the plugs as a corrosion barrier.

1. **Make sure the sealing plate is in the “half open” position.** The arrow in Figure 2.12 indicates the correct position.

Tip: To aid in loading samples, either mark the well location with a laboratory marking pen or wet the well-locating decal and apply it to the front of the glass plate so that the appropriate edge outlines the sample wells.

2. **Lower each module into the tank, seating it in the locating slots.** The module seats properly in only one orientation: with the banana plugs toward the center of the tank, the gel facing outward.
3. **Add the appropriate amount of electrophoresis buffer to the tank.**

General guidelines: add 1.2–1.6 liters of buffer to the tank when only one module is in place, and 1.1–1.4 liters when two modules are in place.

The minimum and maximum levels are marked. The minimum level ensures that the lower electrode, which is approximately 2 cm from the bottom of the module, is completely submerged. Verify that it is. The maximum level prevents buffer in the tank from entering the upper buffer chamber. Also verify this.

4. **Add the appropriate amount of electrophoresis buffer to the upper buffer chamber.**

Fill the upper buffer chamber to a level 3–5 mm above the notched plate. For a 10.5 cm long gel approximately 100 ml will be required, and for a shorter gel, approximately 75 ml.

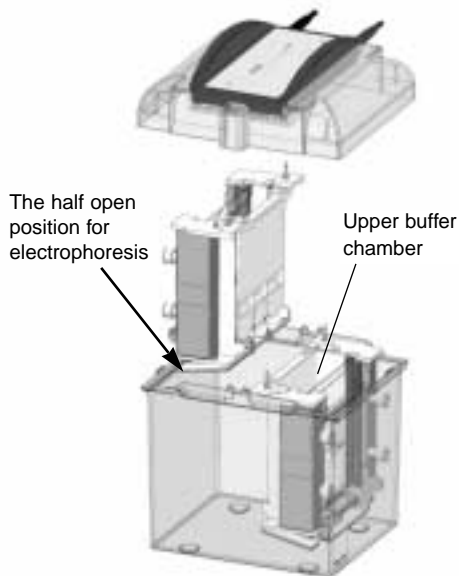

5. Prepare and apply the sample.

Increase liquid sample density with 10% glycerol or sucrose. Add a tracking dye such as phenol red or bromophenol blue.

Underlay the sample into the wells using a micro-pipet or fine-tipped microsyringe. Table 1 shows the volume of sample required for different numbers of wells and comb thicknesses.

Note: The amount of protein sample added to each well depends on both the sensitivity of the staining method and the distribution of protein among separate bands. With Coomassie Blue, it is possible to detect 1 µg in a single band; with the more sensitive silver stains, it is possible to detect as little as 10 ng.

Table 2.1
Well capacities

No. of wells	Volume of sample (µl) per 1 mm depth		
	Comb thickness (mm)		
	0.75	1.0	1.5
5	9.5	12.7	19.1
9		5.8	
10	3.6	4.8	7.2
15	2.2	2.9	4.4
18		2.9	

6. Electrical connections.

Position the safety lid over the unit and seat the lid so the banana plugs engage the jacks in the lid. The lid is symmetrical and fits in either orientation.

Plug the color-coded leads into the jacks of an approved power supply (red to red, black to black). The minimum power supply rating is 250 V, 50 mA, constant current or constant voltage.
(Recommended power supply: EPS 300.)



Figure 2.13
Fully assembled

2.3 Electrophoresis

For optimal resolution, electrophoresis should be started immediately after sample loading.

Important

After initial monitoring, do not leave the unit unattended for more than 30 minutes before checking the buffer level and the progress of the bands.

Gels may be run at either constant current or constant voltage. For Laemmli SDS separations, the recommended voltage range is 100–250 V and should not exceed 300 V. If running gels at constant current, the current should be 10–20 mA per gel, depending on gel thickness (10 mA for 0.75 mm, 15 mA for 1.5 mm).

Check progress after 5 minutes, and again after half an hour, monitoring the position of the tracking dye. The run is complete when the tracking dye reaches the bottom of the gel.

2.4 After electrophoresis

Important

Always disconnect the high voltage leads from the power supply before removing the lid from the unit.

1. Turn off the power supply and disconnect the leads.
2. Remove the safety lid and lift out the module(s).
3. **Release each gel sandwich or cassette from the module:** Move the sealing plate to the fully open position by pressing inward on both tabs and guiding the plate to open out. Then unscrew all four screws 4–5 turns in the counterclockwise direction. Swing the clamps outward.
4. **Remove the gel from the sandwich or cassette.**

Gently loosen and then slide away both spacers. Slip an extra spacer or the Hoefer Wonder Wedge into the **bottom** edge (to prevent breaking the “ears” of the notched plates) and separate the plates.

If using precast gels, follow gel manufacturer’s instructions.

Carefully lift the gel from the plate and lay it into a tray containing stain, fixative, or transfer buffer.

5. Clean the unit as described in Section 2.5.

2.5 Care and Maintenance

- ▶ Do not autoclave or heat any part above 75 °C.
- ▶ Do not immerse the safety lid in any liquid.
- ▶ Do not use organic solvents, strong or oxidizing cleaning solutions, abrasives, or strong acids or bases on any part of the instrument.

Immediately after each use, rinse the tank and modules with water and then rinse thoroughly with distilled water. Handle the module with care to prevent damage to the banana plugs. Allow to air dry.

Wipe the lid with a damp cloth. If necessary, briefly rinse the underside of the lid with water.

Clean glass plates and spacers with a dilute solution of a laboratory detergent such as RBS-35[®], then rinse thoroughly with tap and distilled water. Glass plates can be treated with (but not stored in) acid cleaning solutions. A final wipe with isopropanol will remove any GelSeal residue.

2.6 Troubleshooting

Unusually slow (or fast) run

Reagent and solution factors

- ✓ Check recipes, gel concentrations, solutions, and dilutions. (e.g., do not use Tris-HCl instead of Tris.)
- ✓ If the required pH of a solution is exceeded, do not back-titrate. Prepare fresh buffer.
- ✓ Use only stock of the highest quality. Dispose of outdated acrylamide solutions.
- ✓ Only use freshly deionized urea.

Voltage or current settings

- ✓ To increase or decrease the migration rate, adjust the voltage or current by 25–50%.

Stained sample collects:

Near the buffer front

- ✓ Protein or nucleic acid is not sufficiently restricted by the resolving gel; increase the % T.

Near the top of the gel when the buffer front has reached the bottom

- ✓ The gel pore size is too small. Decrease the % T of the resolving gel.
- ✓ Protein precipitates or the DNA becomes denatured. Decrease the temperature at which the sample is prepared to 70 °C or less, and limit exposure to heat to 1–2 minutes.

Smile effect on the buffer front

To reduce the running temperature:

- ✓ Prechill the buffer.
- ✓ Decrease the current or voltage setting. (Laemmli gel guidelines: 10 mA per 0.75 mm gel, 15 mA per 1.5 mm thick gel.)
- ✓ Conduct electrophoresis in the cold room.
- ✓ Fill the tank to the maximum (marked) buffer level.

Bands are skewed or distorted

Gel preparation

- ✓ Deaerate the stacking gel solution and avoid trapping air bubbles under the comb teeth.
- ✓ Overlay the monomer solution with water-saturated n-butanol to avoid forming an uneven gel surface.

Sample preparation

- ✓ Dialyze or desalt the sample.
- ✓ Centrifuge or filter the sample to remove particulates.

Poor band resolution

- ✓ Use only the highest quality reagents.
- ✓ Only use freshly deionized urea.
- ✓ Use only gels that were recently prepared.
- ✓ Check pH values of the resolving and stacking gel solutions. Do not back-titrate buffers.
- ✓ Conduct the separation at a lower current or voltage setting.

Sample preparation

- ✓ Dialyze or desalt the sample.
- ✓ Reduce the sample volume or concentration.
- ✓ Improve dissociation of protein subunits by heating sample in SDS sample buffer 1–2 minutes at 100 °C. Store on ice after heating.
- ✓ Store sample on ice before it is denatured.
- ✓ Add protease inhibitors if necessary to prevent proteolytic degradation of sample.
- ✓ Add more mercaptoethanol or dithiothreitol; check sample treatment.
- ✓ Store samples to be frozen in aliquots to prevent repeated thawing. Store at -40 °C to -80 °C.

Protein streaks vertically

- ✓ Centrifuge or filter the sample to remove particulates.
- ✓ Dialyze or desalt the sample.

Bromophenol blue doesn't sharpen into a concentrated zone in the stacking gel

- ✓ Pour a taller stacking gel. (For best results, allow a stacking gel height of 2.5 times the height of the sample in the well.)
- ✓ Dispose of outdated acrylamide solutions and use only the highest grade of acrylamide.
- ✓ When preparing samples, avoid using solutions with a high sodium or potassium concentration.

3 The Blot Module (ordered separately)

The Hoefer miniVE blot module, ordered separately, performs electrotransfers on mini-format gels. Each module holds up to two gels, 8.2 cm wide and up to 10.4 cm long. One or two modules can be run at one time.

3.1 Assembly

1. Prior to use, wash the tank and blot module with a dilute solution of non-abrasive laboratory detergent. Thoroughly rinse with water and distilled water.
2. **Install the gaskets.** Separate out two of the four strands of gaskets included with each module.

Open the module by unlatching both tabs. Lay a gasket along the entire groove around each cup half. Avoid stretching or twisting the gasket; the length should just fit. Gently press into place.

Figure 3.1
Install a gasket into each cup half.

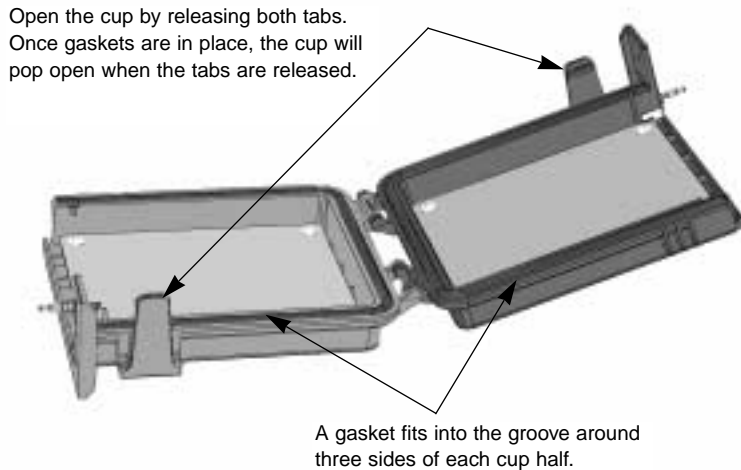

3.2 Preparation

3.2.1 Optional: Passive cooling

Chill approximately 2 liters of deionized water to 4 °C. (Filling the tank with chilled water serves as a heat sink during electrotransfer.)

3.2.2 Prepare transfer buffer

Transfer buffer is required for stack assembly (≈250 ml) and to fill each module (300–350 ml per module). The recipe for the commonly used Towbin buffer is listed below. The Bibliography lists sources for other buffers.

Towbin buffer

(25 mM Tris, 192 mM glycine, 0-20% v/v methanol, pH 8.3, 1 liter)

Tris (FW 121.1)	25 mM	3.0 g
Glycine (FW 75.07)	192 mM	14.4 g
SDS ^a (FW 288.4)	0.1% (3.5 mM)	1.0 g

^aOptional: Adding SDS can improve transfer efficiency.

1. Dissolve in 750 ml distilled water.
2. **Add methanol as required.** Depending on the membrane type selected, adding methanol can improve the transfer results. Because buffers containing methanol may deteriorate if stored for long periods, add methanol just prior to transfer.
3. Bring to 1 liter with distilled water. Do not adjust the pH, which should be between 8.2 and 8.4.
4. Optional: Chill before use.

3.3 Prepare the transfer stack

Transfer the sample as soon as possible after electrophoresis to minimize sample diffusion within the gel. Electrophoretic transfer can be performed on as many as four mini gels at one time if two gels are placed in each of two modules.

1. The transfer stack consists of the gel and membrane, filter paper, and three packing sponges. The gel determines the size of the membrane and filter paper: for each gel cut the membrane and two pieces of filter paper the same size as the gel, but no larger than 8.5 × 10.5 cm.

2. Equilibrate the **gel** in transfer buffer for 10 minutes. Equilibration allows the gel to swell or shrink before it contacts the transfer membrane and removes excess buffer salts and detergents from the gel. Longer equilibration may result in diffuse bands.
3. The **transfer membrane** is prepared in two steps:
 - a. Pre-wet **nitrocellulose or nylon membranes** in distilled water, taking care not to trap air bubbles: dip one end of the membrane into the buffer and slowly submerge, allowing it to wet by capillary action. Pre-wet **PVDF or other hydrophobic membranes** in methanol.
 - b. After prewetting, soak all membrane types in transfer buffer for 2–5 minutes.
4. Wet the two pieces of **filter paper** in transfer buffer.
5. Assemble the transfer stack so that molecules will migrate to the membrane. For negatively charged macromolecules (such as proteins run in an SDS gel and nucleic acids), assemble the transfer stack on the black cathode side.

Note: For best results, care should be taken to avoid trapping air bubbles as each layer is applied. This is best accomplished by always establishing full contact along one side and maintaining it as the layer is lowered into position.

See step 5 for proper orientation.

- a. Center a packing sponge on the black cathode side.
- b. Lay one piece of wet filter paper on the sponge.
- c. Position the equilibrated gel on the filter paper. Wet the gel surface with a few drops of transfer buffer.
- d. Lay the membrane on the gel. Do not reposition the membrane once it contacts the gel.
- e. Lay one piece of wet filter paper on the membrane.
- f. Lay two packing sponges on the filter paper. A **second transfer stack**, if added, is placed between these two sponges: Repeat steps b–e.

Figure 3.2
Transfer stack assembly

The module is color coded:
black = cathode (–)
red = anode (+)

Important

Try to place the gel correctly the first time because proteins may begin to transfer immediately; once transfer has begun, moving the gel will distort results or cause “shadow bands” on the blot.

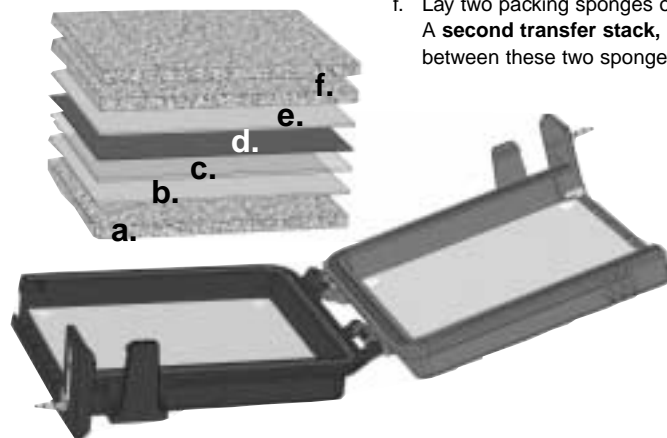

7. Check the position of the transfer stack. It should be centered on the electrode plate; no layer should be pinched when the module is closed. Fold the empty half of the cup over the stack and press the halves together to snap the module closed.

3.4 Final assembly

Note

Avoid wetting the banana plugs with electrophoresis buffer. A protective film of GelSeal™ (supplied) can be applied to the plugs as a corrosion barrier.

1. Pour 300–350 ml of transfer buffer into the top of the module. Tap the blotting cup *lightly* to dislodge any air bubbles in the packing sponges.
2. Position the module(s) in the tank with the banana plugs toward the center (the red side facing outward).
3. Add deionized water to the tank: 1.7 liters for one module and 1.2 liters for two modules.

Buffer temperature should not exceed 75 °C to avoid rapid evaporation. Passive cooling is recommended if the transfer will be longer than one hour, if biological activity must be protected, or if transferring nucleic acids. Chill deionized water to (4 °C) before adding to the tank.

4. Place the safety lid on the tank. (Either orientation fits and is correct.) Plug the color-coded leads into the jacks of an approved power supply (such as the EPS 300): red to red, black to black.

Figure 3.3

Final assembly

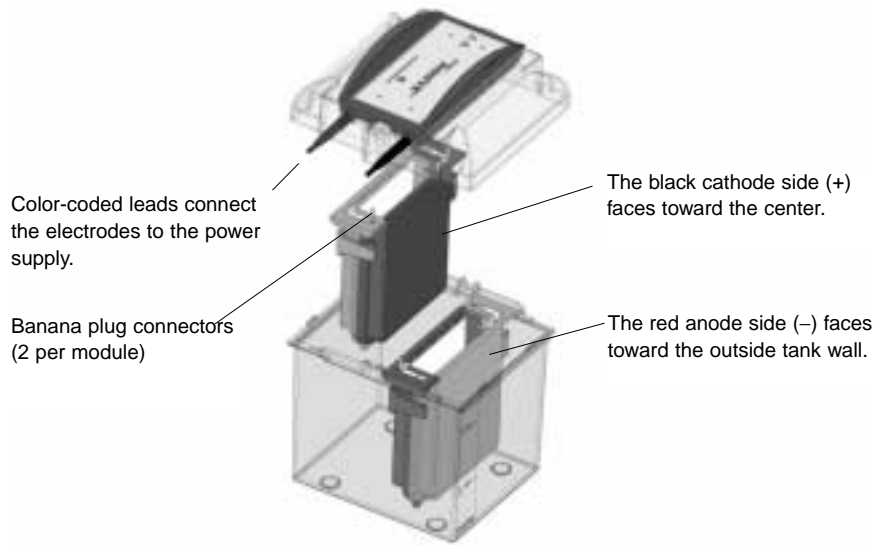

3.5 Electrotransfer

Note

Never leave the unit unattended for more than one hour once electrotransfer has begun.

Note

300–350 ml Towbin buffer contains sufficient buffering capacity for a transfer period of up to 2 hours at 300 mA.

Electrophoretic transfer conditions for blotting proteins in Towbin buffer: 25 V for 1–2 hours, 300–400 mA.

Important: We recommend programming the power supply to **hold the current setting constant** to avoid possible overheating, especially if no passive cooling is in place. (Buffer conductivity increases with increasing temperature, providing a positive feedback that results in rapid heating.) If the only programming option is to hold the voltage setting constant, monitor and adjust the voltage to maintain the current at or below 400 mA.

3.6 After electrotransfer

1. Turn off the power supply and disconnect the leads.
2. Remove the safety lid. Lift out the module(s) and drain by inverting over a sink. Avoid wetting the banana plugs with buffer.
3. Open the module. Remove the gels and membranes. Save the packing sponges. Discard the blotting paper.
4. Label each membrane and indicate the sample side. Lift the membrane(s) with blunt forceps and allow to air dry.
5. Rinse the unit immediately after use.

3.7 Care and Maintenance

- Do not autoclave or heat any part above 75 °C.
- Do not use organic solvents, strong or oxidizing cleaning solutions, abrasives, or strong acids or bases on any part of the instrument.

Immediately after each use, rinse the unit with water and then rinse thoroughly with distilled water. Handle the module with care to prevent damage to the electrode plugs. Allow to air dry.

3.8 Troubleshooting

Incomplete transfer

Blank areas on the membrane

- ✓ Remove all trapped air bubbles in the transfer stack; take especially great care during stack assembly to prevent air bubbles from forming as each layer is placed.
- ✓ Check electrode continuity.
- ✓ Use a lower ionic strength buffer.

Molecules do not migrate out of gel

- ✓ Increase the field strength.
- ✓ Increase the transfer period. (Try doubling it.)
- ✓ Do not expose the gel to staining or fixing agents before transfer.
- ✓ Use a thinner gel.
- ✓ Reduce the gel acrylamide concentration.
- ✓ For proteins, use 3.5 mM SDS (0.1%) in the transfer buffer.
- ✓ Avoid using methanol in the protein transfer buffer or reduce the amount to a minimum.
- ✓ Use reagent grade chemicals.
- ✓ Increase the length of time Southern blots are depurinated.
- ✓ Check the buffer pH. Most buffers should not be titrated; make fresh buffer.
- ✓ Increase the net charge on the protein by changing to a transfer buffer with a different pH. Lower pH (<6-7) increases the positive charge on proteins; higher pH (>6-7) increases the negative charge on proteins.

Diffuse band patterns

- ✓ Conduct the electrotransfer immediately after electrophoretic separation.
- ✓ Shorten or eliminate the equilibration step before electrotransfer, or conduct equilibration in the cold room.
If the transfer buffer contains methanol ($\geq 10\%$), however, equilibrate the gel for 30 minutes to allow it to shrink fully. Note: Gel shrinkage may slow the migration of large molecules.

- ✓ Take care that the gel does not shift once it contacts the membrane.
- ✓ Check that the preferred binding surface of the membrane faces the gel.

Inefficient binding to membrane

Chemical parameters

- ✓ Fix or crosslink the molecule onto the membrane according to the requirements of the nucleic acid, protein, or membrane type.
- ✓ Prepare protein transfer buffer **without** SDS.
- ✓ Verify the optimal amount of methanol required for the membrane type and check the buffer solution. Add 10–20% methanol to the transfer buffer to enhance binding to nitrocellulose.

Membrane parameters

- ✓ Wear gloves when handling membranes.
- ✓ Store membranes properly (*e.g.* protect from temperature extremes and direct sunlight).
- ✓ If proteins pass through the selected membrane, try a different type or one with a smaller pore size (0.10–0.20 μm).
- ✓ Place a membrane on both sides of the gel if different proteins may be migrating in opposite directions.
- ✓ If the sample load may be exceeding the capacity of the binding surface area, apply two membranes. If "blow through" occurs, reduce the sample load.

4

Bibliography**4.1 Polyacrylamide gel electrophoresis**

- Adams, L.D. and Gallagher, S.R., Two-Dimensional Gel Electrophoresis Using the O'Farrell System. *Current Protocols in Molecular Biology*, 10.4.1–10.4.13 (1992).
- Gallagher, S.R., and Smith, J.A., Electrophoretic separation of proteins. *Current Protocols in Molecular Biology*. (F.A. Ausubel, R. Brent, R.E. Kingston, D.D. Moore, J.G. Seidman, J.A. Smith, and K. Struhl, eds.) 10.2.1–10.2.21 (1991).
- Laemmli, U.K., Cleavage of structural proteins during the assembly of the head of bacteriophage T4. *Nature*. **227**, 680–685 (1970).
- Matsudaira, P.T. and Burgess, D.R., SDS microslab linear gradient polyacrylamide gel electrophoresis. *Anal. Biochem.* **87**, 386–396 (1978).
- Reisfeld, R.A., *et al.* Acidic buffer system for resolution of cationic proteins. *Nature*. **195**, 281 (1962).
- Sasse, J., and Gallagher, S.R., Staining proteins in gels. *Current Protocols in Molecular Biology*. (F.A. Ausubel, R. Brent, R.E. Kingston, D.D. Moore, J.G. Seidman, J.A. Smith, and K. Struhl, eds.) 10.6.1–10.6.8 (1991).
- Weber, K., and Osborn, M., The reliability of molecular weight determinators by dodecyl sulfate-polyacrylamide gel electrophoresis. *J. Biol. Chem.* **224**, 4406–4412 (1969).

4.2 Blotting

- Gallagher, S., Winston, S.E., Fuller, S.A. and Hurrell, J.G.R., Immunoblotting and Immunodetection. In *Current Protocols in Molecular Biology*. 10.8.1–10.8.17. Greene Publishing and Wiley-Interscience, NY (1993).
- Gershoni, J.M., and G.E. Palade Protein Blotting: Principles and Applications. *Anal. Biochem.* **131**, 1–15 (1983).
- Harlow, E. and Lane, D., *Antibodies: A Laboratory Manual*, Cold Spring Harbor Press, (1988).
- Sambrook, J., *et al.* *Molecular Cloning: A Laboratory Manual*, Cold Spring Harbor Laboratory Press, B.23 (1989).
- Towbin, H., Staehelin, T., and Gordon, J., Electrophoretic transfer of proteins from polyacrylamide gels to nitrocellulose sheets: procedure and some applications. *Proc. Natl. Acad. Sci. USA*. **76**, 4350–4354 (1979).

5 Customer Service Information

Technical Service and Repair

Amersham Biosciences offers complete technical support for all our products. If you have any questions about how to use this product, or would like to arrange to repair it, please call or fax your local Amersham Biosciences sales office or representative.

Important: Request a copy of the “Health and Safety Declaration” Form before returning the item. No items can be accepted for servicing or return unless this form is properly completed.

Ordering Information

	Qty.	Code No.
Hoefler miniVE Basic: includes two gel modules, lid and tank.	1	80-6418-58
Hoefler miniVE, complete: includes 3 rectangular glass plates, 3 notched plates, 2 gel modules, lid, tank, 2 each 1.0 mm thick 10 well combs and 1.0 mm thick spacer sets.	1	80-6418-77
Adaptors for use with Novex precast gels	4/pk	80-6421-24
Blot Module, includes 3 Dacron sponges (¼" thick), 25 sheets of blotter paper	1	80-6418-96

Accessories

Glass plates, 10 x 10.5 cm	5/pk	80-6150-87
Notched glass plates, 10 x 10.5 cm	5/pk	80-6150-49
Spacers, 0.75 mm thick	pair	80-6149-92
Spacers, 1.0 mm thick	pair	80-6150-11
Spacers, 1.5 mm thick	pair	80-6150-30
Comb; 5 well, 0.75 mm thick	1	80-6140-23
Comb; 5 well, 1.0 mm thick	1	80-6140-42
Comb; 5 well, 1.5 mm thick	1	80-6140-61
Comb; 9 well, 1.0 mm thick (microtiter)	1	80-6140-80
Comb; 10 well, 0.75 mm thick	1	80-6138-71
Comb; 10 well, 1.0 mm thick	1	80-6138-90
Comb; 10 well, 1.5 mm thick	1	80-6139-09
Comb; 15 well, 0.75 mm thick	1	80-6139-47

Comb; 15 well, 1.0 mm thick	1	80-6139-66
Comb; 15 well, 1.5 mm thick	1	80-6139-85
Comb; 18 well, 1.0 mm thick (microtiter)	1	80-6140-04
Comb; prep/ref., 0.75 mm thick	1	80-6141-56
Comb; prep/ref., 1.0 mm thick	1	80-6141-75
Comb; prep/ref., 1.5 mm thick	1	80-6141-94

Gel Casters, Hoefer SE 200 Series

SE 245 Mighty Small Dual Gel Caster, 1 or 2 gels, 10 x 8, -10.5 cm	1	80-6146-50
SE 215 Mighty Small Multiple Gel Caster, 5 to 10 gels, 10 x 8 cm	1	80-6142-51
SE 275 Mighty 4-Gel Caster, 2 to 4 gels, 10 x 8 cm	1	80-6151-06
SE 235 Mighty 4-Gel Caster, 2 to 4 gels, 10 x 10.5 cm	1	80-6146-12

Electrophoresis Power Supplies

EPS 300 Power Supply, 300 V, 400 mA, 80 W	1	18-1123-97
Hoefer EPS 2A200 Power Supply, 200 V, 2000 mA, 200 W	1	80-6406-99

Gel Drying System

Hoefer EasyBreeze Air Gel Dryer 115 V	1	80-6121-61
Hoefer EasyBreeze Air Gel Dryer 230 V	1	80-6121-80

Protein Molecular Weight Markers

LMW Marker Kit	1	17-0446-01
HMW-SDS Marker Kit	1	17-0615-01
HMW Marker Kit	1	17-0445-01

PlusOne™ Chemicals

Acrylamide PAGE	250 g	17-1302-01
Acrylamide PAGE	1 kg	17-1302-02
Acrylamide PAGE 40% solution	1000 ml	17-1303-01
Acrylamide IEF	250 g	17-1300-01
Acrylamide IEF 40% solution	1000 ml	17-1301-01
N,N' -methylenebisacrylamide	100 g	17-1304-02
N,N' -methylenebisacrylamide 2% solution	1000 ml	17-1305-01
Ammonium persulfate	25 g	17-1311-01
TEMED	25 ml	17-1312-01
Tris	500 g	17-1321-01
Boric Acid	500 g	17-1322-01
EDTA, disodium salt	100 g	17-1324-01
Urea	500 g	17-1319-01
Silver Staining Kit, Protein	1	17-1150-01
Silver Staining Kit, DNA	1	17-6000-30

Amersham Life Science Products

Rainbow colored molecular weight markers (low molecular weight)	1	RPN755
Rainbow colored molecular weight markers (high molecular weight)	1	RPN756
Rainbow colored molecular weight markers (full range)	1	RPN800
ECL Protein molecular weight markers with Strep-HRP	1	RPN2280
ECL Western blotting molecular weight markers	1	RPN2107
ECL Plus Western blotting detection system	1	RPN2132
ECL Western blotting reagents (sufficient for 1000 cm ² of membrane)	1	RPN2109
ECL Western blotting reagents (sufficient for 2000 cm ² of membrane)	1	RPN2209
ECL Western blotting reagents (sufficient for 4000 cm ² of membrane)	1	RPN2106
ECL Western blotting system (kit; sufficient for 1000 cm ² of membrane)	1	RPN2108
Hybond-C Super supported pure nitrocellulose, 12 x 10 cm	20/pk	RPN1210G
Hybond-C nitrocellulose membrane, 12 x 10 cm	20/pk	RPN1210C
Hybond-C pure nitrocellulose membrane, 20 x 20 cm	10/pk	RPN2020W
Hybond-C pure nitrocellulose membrane, 20 cm x 3 m	roll	RPN203W
Hybond-C pure nitrocellulose membrane, 30 cm x 3 m	roll	RPN303W
Hybond-P, PVDF membrane, 20 x 20 cm	10/pk	RPN2020F
Hybond-P, PVDF membrane, 30 cm x 3 m	roll	RPN303F
Hybond ECL nitrocellulose membrane, 20 x 20 cm	10/pk	RPN2020D
Hybond ECL nitrocellulose membrane, 6 x 8 cm	50/pk	RPN68D
Hybond ECL nitrocellulose membrane, 30 cm x 3 m	roll	RPN303D
Hyperfilm ECL, 12.5 x 17.5 cm	25/pk	RPN1674H
Blotter paper, 7 x 8 cm	25/pk	80-6211-48
Blotter paper, 9 x 10.5 cm	50/pk	80-6205-40
Nitrocellulose, 0.45 µm pore size, 9 x 10.5 cm	10/pk	80-6221-17
Nitrocellulose, 0.45 µm pore size, 33 cm x 3 m	roll	80-6221-55
Nitrocellulose, 0.20 µm pore size, 33 cm x 3 m	roll	80-6220-22
Nylon 66 Standard, 0.45 µm pore size, 33 cm x 3 m	roll	80-6221-93
Nylon Standard (GeneBind), 0.45 µm pore size, 20 cm x 3 m	roll	80-1247-87
Nylon 66 Plus (charged), 0.45 µm pore size, 33 cm x 3 m	roll	80-6221-74

2-D Instruments and Accessories

IPGphor System 115/230 V (Order Strip Holders separately)	1	80-6414-02
7 cm Strip Holder, complete for use with Immobiline Drystrip IPG gels	6/pk	80-6416-11
Immobiline DryStrip, pH 4-7 L, 7 cm	12/pk	17-6001-10
Immobiline DryStrip, pH 3-10 L, 7 cm	12/pk	17-6001-11
Immobiline DryStrip, pH 3-10 NL, 7 cm	12/pk	17-6001-12

Notes

T a b l e o f C o n t e n t s

1. MINiVE ELECTROPHORESIS UNIT FUNCTION AND DESCRIPTION	1
1.1 SPECIFICATIONS	2
1.2 IMPORTANT INFORMATION	3
1.3 UNPACKING	4
2. THE ELECTROPHORESIS MODULE	5
2.1 PREPARING THE GEL	5
2.2 FINAL ASSEMBLY.	11
2.3 ELECTROPHORESIS.	13
2.4 AFTER ELECTROPHORESIS	13
2.5 CARE AND MAINTENANCE.	14
2.6 TROUBLESHOOTING.	14
3. THE BLOT MODULE	17
3.1 ASSEMBLY.	17
3.2 PREPARATION.	18
3.3 PREPARE THE TRANSFER STACK.	18
3.4 FINAL ASSEMBLY.	20
3.5 ELECTROTRANSFER.	21
3.6 AFTER ELECTROTRANSFER	21
3.7 CARE AND MAINTENANCE.	21
3.8 TROUBLESHOOTING.	22
4. BIBLIOGRAPHY	24
5. CUSTOMER SERVICE INFORMATION	25

Renseignements importants d'utilisation

Pour une bonne compréhension et une utilisation en sécurité maximale, il convient de lire entièrement ce manuel.



Dans la documentation qui accompagne l'instrument un point d'exclamation dans un triangle équilatéral a pour but d'attirer l'attention de l'utilisateur sur des instructions importantes de fonctionnement ou de maintenance.



Le symbole de l'éclair dans un triangle équilatéral a pour objet d'attirer l'attention de l'utilisateur sur un danger d'exposition à la haute tension.

Tous vos commentaires sur ce manuel seront les bienvenus et veuillez les adresser à:

Amersham Biosciences
Marketing Department
654 Minnesota Street
San Francisco, CA 94107 USA

Amersham Biosciences se réserve le droit d'effectuer des modifications de ces spécifications sans aucun préavis.

Garantie et responsabilité

Amersham Biosciences garantit à l'utilisateur que le produit livré a subi avec succès tous les essais prévus pour s'assurer qu'il est conforme aux spécifications et normes en vigueur. La garantie incluse dans les conditions de livraison n'est valable que si le produit a été installé et utilisé conformément aux instructions fournies par Amersham Biosciences.

La société Amersham Biosciences ne sera en aucun cas responsable de tout dommage causé directement ou indirectement par toute utilisation incorrecte ou non approuvée du produit ou découlant de cette utilisation, y compris toute perte de bénéfice ou de recettes, toute perte de perspectives commerciales, tout empêchement d'utilisation et tout autre risques ayant un rapport avec l'utilisation du produit, mais sans aucune limitation quant à la nature de ces dommages.

Copyright© 1998 Amersham Biosciences

Tous droits réservés. La reproduction, le stockage dans un système de récupération d'informations ou la transmission sous quelque forme que ce soit et par quelque moyen que ce soit de la présente publication en totalité ou en partie sont strictement interdits sans autorisation préalable écrite de la société.

Wichtige Benutzerinformationen

Für ein vollständiges Verständnis und eine sichere Handhabung dieses Produktes ist es notwendig, daß der Benutzer dieses Handbuch vollständig durchliest.



Ein Ausrufezeichen in einem gleichseitigen Dreieck soll den Benutzer auf die Anwesenheit wichtiger Betriebs- und Wartungsanweisungen in der dem Gerät beiliegenden Dokumentation hinweisen.



Ein Blitzsymbol in einem gleichseitigen Dreieck soll den Benutzer auf die Gefahr anliegender Hochspannungen hinweisen.

Wenn Sie Anmerkungen zu diesem Handbuch haben, dann senden Sie diese bitte an:

Amersham Biosciences
Marketing Department
654 Minnesota Street
San Francisco, CA 94107 USA

Amersham Biosciences behält sich das Recht vor, die Spezifikationen ohne vorhergehende Ankündigung zu ändern.

Gewährleistung and Haftung

Amersham Biosciences garantiert, daß das gelieferte Produkt sorgfältig auf die Einhaltung der veröffentlichten Spezifikationen getestet wurde. Die in den Lieferbedingungen näher erläuterten Gewährleistungsansprüche gelten nur dann, wenn das Produkt gemäß den von Amersham Biosciences gelieferten Anweisungen installiert und benutzt wurde.

Amersham Biosciences übernimmt keinerlei Haftung für Schäden oder Folgeschäden, einschließlich, aber nicht begrenzt auf Gewinneinbußen, Einkommensverluste, entgangene Geschäftsabschlüsse, Verlust der Gebrauchsfähigkeit oder andere Verluste, die wie auch immer durch eine fehlerhafte oder unsachgemäße Verwendung des Produktes verursacht wurden.

Copyright© 1998 Amersham Biosciences

Alle Rechte vorbehalten. Die vorliegende Veröffentlichung darf nur mit vorhergehender schriftlicher Genehmigung durch das Unternehmen vervielfältigt, in einem Abrufsystem gespeichert oder in irgendeiner Form oder mit irgendwelchen Mitteln übertragen werden.

Informazioni importanti per l'operatore

Per un utilizzo sicuro del prodotto, leggere attentamente l'intero contenuto del presente manuale.



Il punto esclamativo all'interno di un triangolo equilatero indica all'operatore la presenza di importanti istruzioni di funzionamento e manutenzione nella documentazione allegata al prodotto.



Il simbolo del fulmine all'interno di un triangolo equilatero indica all'utente la presenza di un rischio di esposizione ad alte tensioni.

Si prega di inviare eventuali commenti al presente manuale a:

Amersham Biosciences
Marketing Department
654 Minnesota Street
San Francisco, CA 94107 USA

Amersham Biosciences si riserva il diritto di apportare modifiche ai dati tecnici senza preavviso.

Garanzia e responsabilità

Amersham Biosciences garantisce che prima della consegna il prodotto è stato collaudato a fondo per soddisfare i requisiti specificati. La garanzia inclusa nelle condizioni di consegna risulta valida solamente se il prodotto è stato installato ed utilizzato nel rispetto delle istruzioni fornite da Amersham Biosciences .

Amersham Biosciences non potrà essere ritenuta responsabile di incidenti o danni consequenziali, inclusi' ma non limitati' a perdite di profitti, mancato guadagno, perdite di affari, difetti di funzionamento e relative esposizioni, dovuti ad un utilizzo non corretto del prodotto.

Copyright© 1998 Amersham Biosciences

Tutti i diritti riservati. Nessuna parte della presente pubblicazione può essere riprodotta, conservata in sistemi di gestione dati o trasmessa in alcun forma né per nessuno scopo senza autorizzazione scritta del produttore.

Información importante para el usuario

Para comprender el producto y utilizarlo con seguridad es necesario leer este manual en su totalidad.



El signo de admiración en un triángulo equilátero en el manual, advierte al usuario sobre la presencia de instrucciones importantes de operación y mantenimiento del aparato.



El símbolo del rayo en un triángulo equilátero alerta al usuario sobre el riesgo de exposición a altas tensiones.

Si desearan hacer algún comentario sobre este manual, tengan la amabilidad de remitirlo a:

Amersham Biosciences
Marketing Department
654 Minnesota Street
San Francisco, CA 94107 USA

Amersham Biosciences se reserva el derecho a modificar las especificaciones sin previo aviso.

Garantía y responsabilidad

Amersham Biosciences garantiza que el producto entregado ha sido probado a fondo para comprobar el cumplimiento de las especificaciones publicadas. La garantía incluida en las condiciones de entrega sólo es válida si el producto se ha instalado y utilizado de acuerdo con las instrucciones entregadas por Amersham Biosciences .

Amersham Biosciences no será responsable, bajo ningún concepto, de daños directos o indirectos, incluyendo sin limitación la pérdida de beneficios, la pérdida de ingresos, la pérdida de oportunidades de negocio, la pérdida de utilización y otras consecuencias relacionadas, cualquiera que sea la causa, que se deban a la utilización defectuosa e incorrecta del producto.

Copyright© 1998 Amersham Biosciences

Reservados todos los derechos. No está permitida la reproducción, ni el almacenaje en un sistema de recuperación, ni la transmisión de parte alguna de esta publicación sin la autorización por escrito de la empresa.

Important user information

Please read this entire manual to fully understand the safe and effective use of this product.



The exclamation mark within an equilateral triangle is intended to alert the user to the presence of important operating and maintenance instructions in the literature accompanying the instrument.



The lightning symbol within an equilateral triangle is intended to alert the user to the risk of exposure to high voltages.

Should you have any comments on this manual, we will be pleased to receive them at:

Amersham Biosciences
Marketing Department
654 Minnesota Street
San Francisco, CA 94107 USA

Amersham Biosciences reserves the right to make changes in the specifications without prior notice.

Warranty and Liability

Amersham Biosciences guarantees that the product delivered has been thoroughly tested to ensure that it meets its published specifications. The warranty included in the conditions of delivery is valid only if the product has been installed and used according to the instructions supplied by Amersham Biosciences.

Amersham Biosciences shall in no event be liable for incidental or consequential damages, including without limitation, lost profits, loss of income, loss of business opportunities, loss of use and other related exposures, however caused, arising from the faulty and incorrect use of the product.

Copyright© 1998 Amersham Biosciences

All rights reserved. No part of this publication may be reproduced, stored in a retrieval system or transmitted in any form by any means, without permission in written form from the company.

